

## NPSIII

Single Pump System with PM Pump or  
Multi-Pump System with PM Pump  
Variable Frequency Drive Pump Stations



### Constant Pressure VFD in an Affordable Package

National Pump Company designed the NPSIII line of pump stations and control packages with versatility in mind! Our NPSIII standard and custom multi-pump configurations cover a broad range of requirements. From industrial and commercial applications, to potable water boosters and agricultural irrigation, there is a NPSIII pump system to meet your needs. NPSIII pump stations are available in vertical turbine, centrifugal, and submersible models, and our standard configurations combine a 5 HP or 15 HP pressure maintenance or jockey pump with VFD driven main pumps up to 75 HP. Custom NPSIII stations and control panels are available in HP ranges up to 200 HP with as many as 3 pumps. Control packages for deep well applications are also available, and all NPSIII systems can be used to convert single-phase power to three phase if needed. If you are looking for a cost effective multiple pump control package, NPSIII has your solution.

### State of the Art Technology and User Friendly Controls

The NPSIII control system incorporates the variable frequency drive's on-board processor and operator interface to create a competitively priced alternative to other VFD systems or antiquated constant speed technology. NPSIII features an intuitive LCD and integrated keypad to allow the operator to make control adjustments and gather a variety of needed data on the pump station's current status and history. The advanced technology of this system displays actual operating pressure directly through the operator interface device, and makes operating system changes as easy as pushing

a few buttons. All standard NPSIII pump packages are U.L. and C.U.L. listed Packaged Pumping Systems and/or Enclosed Industrial Control Panels. Standard control system features include a manual emergency bypass (3 phase models only), circuit breaker disconnects, sine wave tracking surge protection, and VFD input line reactors. Standard safeties include phase protection, high and low discharge pressure, low level (turbine and submersible), high temp (centrifugal), and low inlet (booster applications). A variety of

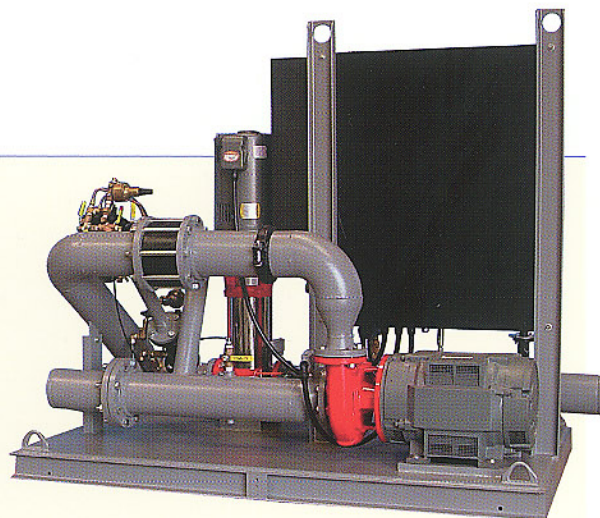

optional controls and safeties are also available, as well as the capability to send flow, fault or status information and receive resets, shut downs or other instructions for remote control or monitoring.



### Innovation in Design

As with all National Pump Packaged Pumping Systems, a great deal of thought goes into the mechanical design and construction of our stations. Structural integrity, flow characteristics, physical dimensions, and appearance are all taken into consideration, as well as ease of installation and serviceability. Although our standard NPSIII models are compact enough to be housed in an optional dual access, powder-coated aluminum enclosure, you will still find ample access to service all equipment. To improve the longevity and finish of our products, National Pump uses a powder-coating process instead of liquid applied paint. Prior to the powder coating and baking process, all steel components are steel grit blasted to bare, white metal. Next, two layers of electrostatically charged polyurethane powder-coating are applied to the already blasted steel components and the unit is then oven baked at a high temperature to provide a uniform finish that is highly resistant to scratching, chipping, and corrosion. All NPSIII standard and custom configurations provide a well engineered balance in mechanical design, functionality, and efficiency.

## Quality Manufacturing

All NPS pump systems are built at our Olive Branch, MS manufacturing facility, where each and every station undergoes a rigorous inspection and documentation process throughout the production process. From control panel design and construction in our U.L. listed panel shop, to fabrication, powder-coating, and assembly, we constantly monitor the quality of our workmanship. As a final assurance, each station is completely assembled, powered up, and tested to design capacity prior to shipment. During this process, the station is fully calibrated which allows for trouble-free installation and start up once the station is delivered. All calibration data and detailed component information is then stored in a database for future reference and technical support should the need arise.

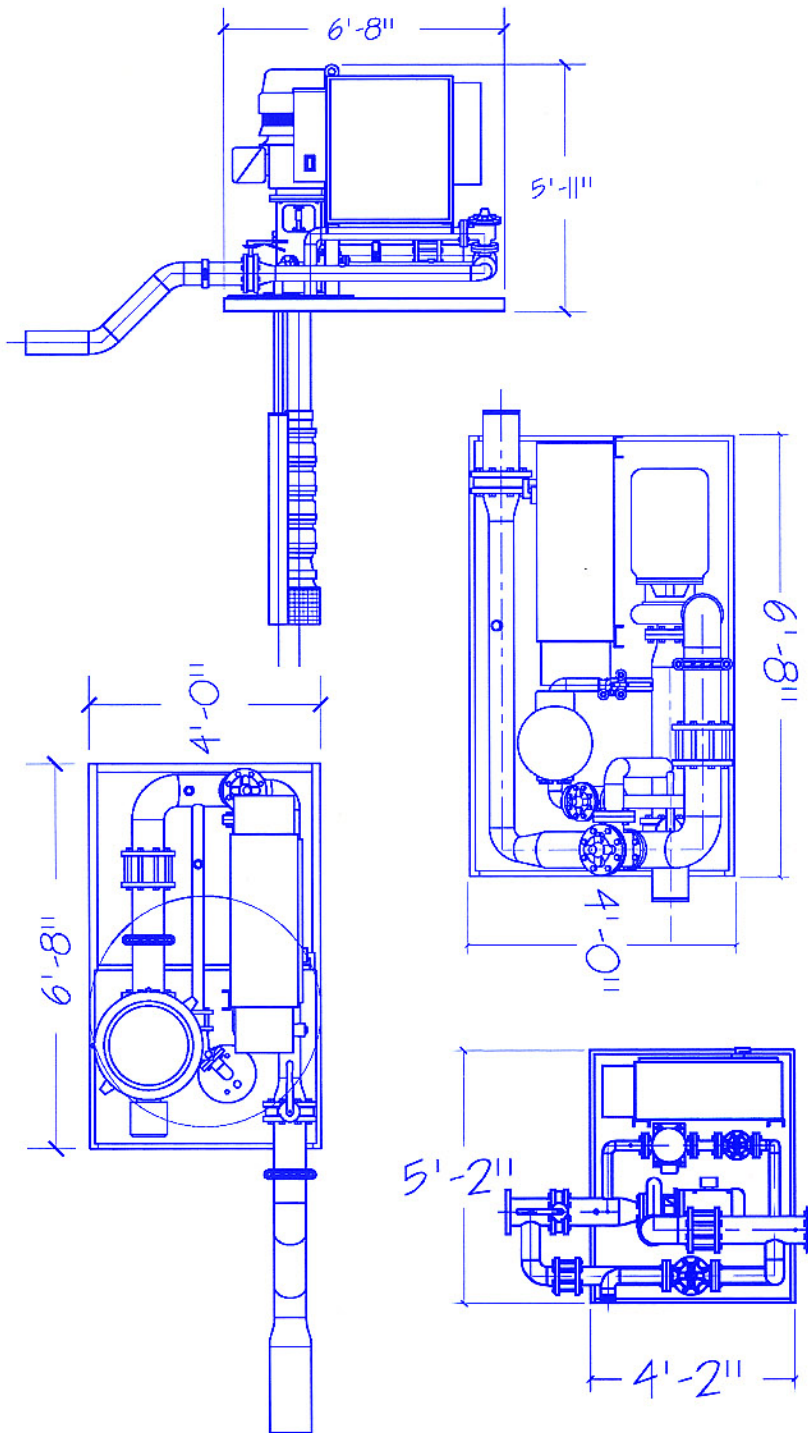

### NPSIII features include:

- Standard model flow rates up to 900 GPM
- Standard 5 or 15 HP pressure maintenance pump with main pumps up to 75 HP
- Custom units with 2 or 3 main pumps up to 200 HP and unlimited capacities
- NPSIII Variable Frequency Drive control system with on-board processor
- Multi-function LCD operator interface terminal
- Adjustable startup ramp, PID tuning, and operating setpoint features
- U.S. and International voltages available, as well as single phase capability in all HP's
- U.L. and C.U.L Listed Packaged Pumping Systems and Control Panels
- Fabricated steel construction with polyurethane powder-coated finish
- Pressure relief valve
- Emergency bypass controls (except single phase models)

### Standard Safeties Include:

- High discharge pressure
- Low discharge pressure
- Low level safety (if applicable)
- High pump temp safety (if applicable)
- Low low inlet pressure (if applicable)
- HMCP motor circuit protection and overload relays
- Incoming phase and voltage monitor
- Primary surge protection

### Optional Features:

- Powder-coated aluminum, dual access station enclosure
- Remote monitor and control capability
- Flowmeter with totalizer
- Station heater
- Inlet and discharge isolation valves and zee pipes
- Intake pipe, foot valve and prime regulator
- Level control circuits
- Filtration and injection systems
- Step down transformer, load center, and power conditioner



**Arizona**  
7600 W. Olive Ave., Peoria, AZ 85345-7102  
(800) 966 5240 Fax: (623) 979 2177

**California**  
2790 South Railroad Ave., Fresno, CA 93725  
(800) 868 9755 Fax: (559) 497 8816

**Florida**  
195 E. 3rd Street, Zolfo Springs, FL 33890  
(800) 994 3045 Fax: (863) 735 8202

**Georgia**  
902 East Union St., Vienna, GA 31092  
(800) 741 2921 Fax: (229) 268 7868

**Mississippi**  
11176 Green Valley Drive  
Olive Branch, MS 38654  
(866) 668 4914 Fax: (662) 895 1107

**Texas**  
3107 Slaton Hwy., Lubbock, TX 79404  
(800) 745 5393 Fax: (806) 745 6668

**N<sup>PC</sup> NATIONAL PUMP COMPANY LLC**

**Delivering Pump Systems,  
Reliability, Dependability and  
Service Since 1969**